

WASHBASIN WASCHBECKEN LAVE-MAINS LAVABO

Installation Guide
Installationsanleitung
Guide d'installation
Manuale di installazione

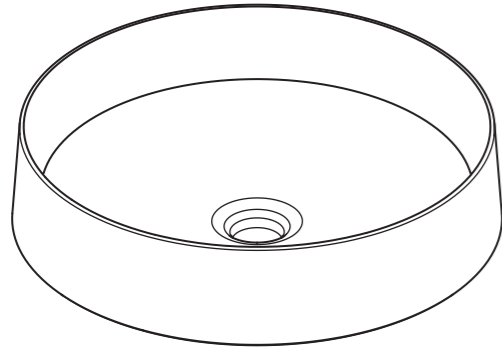

MRZ700

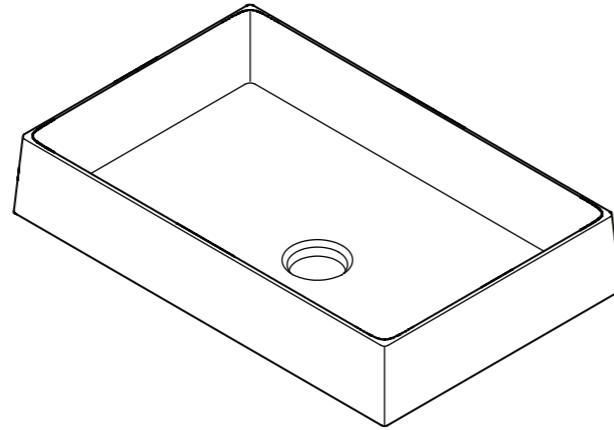

MRZ710

GB

Cautions and warnings

Before installing, be sure to read the following installation instructions. Install the product only as described in this guide. Follow all safety precautions and warnings.

 WARNING	When this appears next to a topic, this indicates that misoperation could result in death or serious injury.	 CAUTION	When this appears next to a topic, this indicates that misoperation may result in injury or physical damage.
--------------------	--	--------------------	--

Symbol example

	The symbol indicates something that is prohibited.		The symbol indicates something that must be done.
--	---	--	--

WARNING	
 Required	<ul style="list-style-type: none"> Install securely, in accordance with the Installation Guide. (Improper installation can cause water leaks that damage or ruin household property.)

CAUTION	
 Prohibited	<ul style="list-style-type: none"> Do not drop any heavy or hard objects in the bowl. (Injury may result from cracks in the bowl or leaking water may contaminate or ruin household property.)

DE

Vorsichtsmaßnahmen und Warnungen

Lesen Sie vor der Installation die folgenden Installationsanweisungen bitte gut durch. Installieren Sie das Produkt bitte nur so, wie es in der Anleitung beschrieben ist. Beachten Sie bitte alle Vorsichtsmaßnahmen und Warnungen.

 WARNUNG	Wenn ein Abschnitt mit diesem Symbol gekennzeichnet ist, wird darauf hingewiesen, dass bei fehlerhafter Handhabung die Gefahr von schweren oder gar tödlichen Verletzungen besteht.	 VORSICHT	Wenn ein Abschnitt mit diesem Symbol gekennzeichnet ist, wird darauf hingewiesen, dass bei fehlerhafter Handhabung möglicherweise Verletzungsgefahr oder die Gefahr von Sachschäden besteht.
--------------------	---	---------------------	--

Beispielsymbole

	Das Symbol gibt an, dass etwas verboten ist.		Das Symbol weist auf etwas hin, das getan werden muss.
--	---	--	---

WARNUNG	
 Erforderlich	<ul style="list-style-type: none"> Installieren Sie das Produkt sicher und befolgen Sie die in dieser Installationsanleitung enthaltenen Anweisungen. (Eine unsachgemäße Installation kann undichte Stellen entstehen, wodurch Ihr Hausrat beschädigt oder zerstört werden könnte.)

VORSICHT	
 Verboten	<ul style="list-style-type: none"> Lassen Sie keine schweren oder harten Gegenstände in das Waschbecken fallen. (Risse in das Waschbecken können zu Verletzungen führen und austretendes Wasser kann Ihren Hausrat beschädigen oder zerstören.)

FR

Mises en garde et avertissements

Avant d'installer, assurez-vous de lire les instructions d'installation suivantes. Installez ce produit en suivant exclusivement la procédure décrite dans ce guide. Suivez toutes les précautions et les avertissements de sécurité.

 AVERTISSEMENT	Lorsque ce symbole apparaît en regard d'une rubrique, cela indique que toute utilisation incorrecte pourrait entraîner la mort ou une blessure grave.	 MISE EN GARDE	Lorsque ce symbole apparaît en regard d'une rubrique, cela indique que toute utilisation incorrecte peut entraîner une blessure ou un dommage physique.
--------------------------	---	--------------------------	---

Exemple de symbole

	Le symbole indique que quelque chose est interdit.		Le symbole indique que quelque chose doit être fait.
--	---	--	---

AVERTISSEMENT	
 Requis	<ul style="list-style-type: none"> Installez convenablement, conformément au Guide d'installation. (Une installation incorrecte peut entraîner des fuites susceptibles de provoquer des dégâts matériels éventuellement irréversibles.)

MISE EN GARDE	
 Interdit	<ul style="list-style-type: none"> Ne laissez pas tomber d'objets lourds ou durs dans le lavabo. (Les fissures dans le lavabo risqueraient de vous blesser et une fuite pourrait souiller vos biens ou les endommager de manière irréversible.)

Avvisi di pericolo e attenzione

Prima di installare, leggere le seguenti istruzioni di installazione. Per l'installazione, adottare esclusivamente le procedure riportate nel presente manuale.

Rispettare tutte le istruzioni di sicurezza e le indicazioni riportate negli avvisi.



PERICOLO

I paragrafi preceduti da questa indicazione contengono descrizioni importanti. In caso di inosservanza, si possono verificare gravi infortuni, anche mortali.



ATTENZIONE

I paragrafi preceduti da questa indicazione contengono descrizioni importanti. In caso di inosservanza, si possono verificare infortuni o danni alle cose.

Esempio di simbolo



Il simbolo  indica operazioni vietate.



Il simbolo  indica operazioni che devono essere eseguite obbligatoriamente.

PERICOLO



Obbligatorio

- Eseguire l'installazione in modo sicuro, attenendosi alle istruzioni del Manuale di installazione. (Un'installazione scorretta può provocare la fuoriuscita di acqua con conseguenti danni agli oggetti o all'edificio.)

ATTENZIONE



Vietato

- Non far cadere oggetti duri o pesanti nel lavandino. (Le eventuali fessurazioni del lavandino potrebbero essere causa di infortuni e, in caso di perdite, si potrebbero sporcare o danneggiare oggetti o parti dell'edificio.)

Included parts / Mitgelieferte Teile Pièces fournies / Parti in dotazione

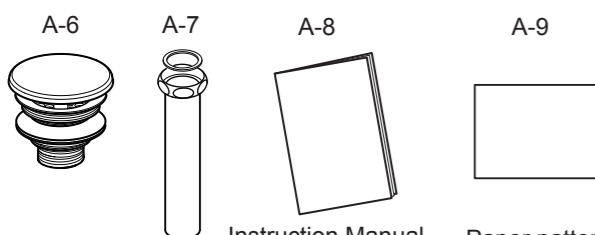
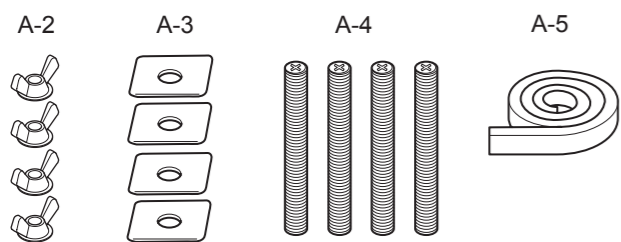
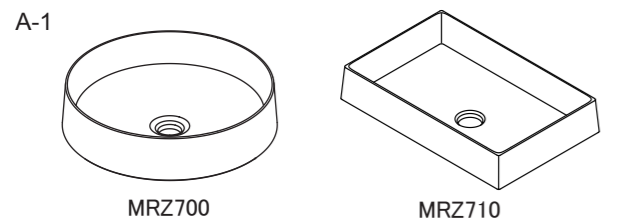

Instruction Manual
Bedienungsanleitung
Manuel d'instructions
Manuale di istruzioni

Paper pattern
Papiervorlage
Gabarit en papier
Dima di carta

Before installation Vor der Installation Avant l'installation Prima dell'installazione

GB

Using the included paper pattern, make an opening for the bowl in the counter.

DE

Schaffen Sie mithilfe der im Lieferumfang enthaltenen Papiervorlage eine Öffnung für das Waschbecken im Waschtisch.

FR

En utilisant le gabarit en papier fourni, découpez une ouverture pour le lavabo dans le comptoir.

IT

Utilizzando l'apposita dima di carta, praticare un foro per il lavandino nel piano di appoggio.

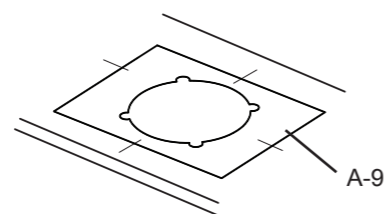

Attach the bowl Anbringen des Waschbeckens Fixez le lavabo Installare il lavandino

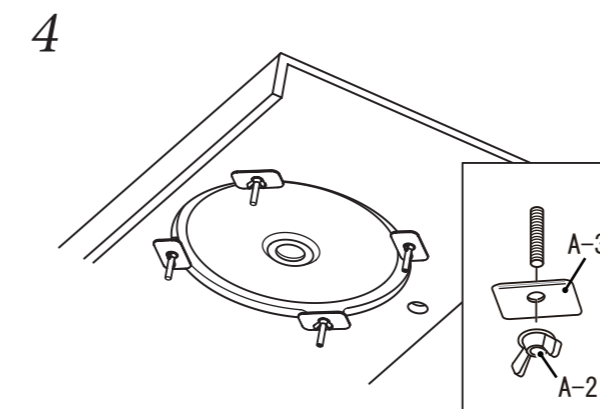
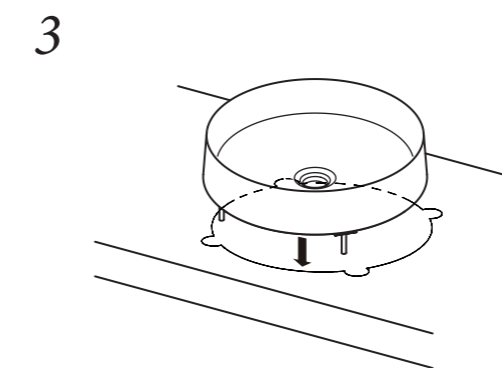
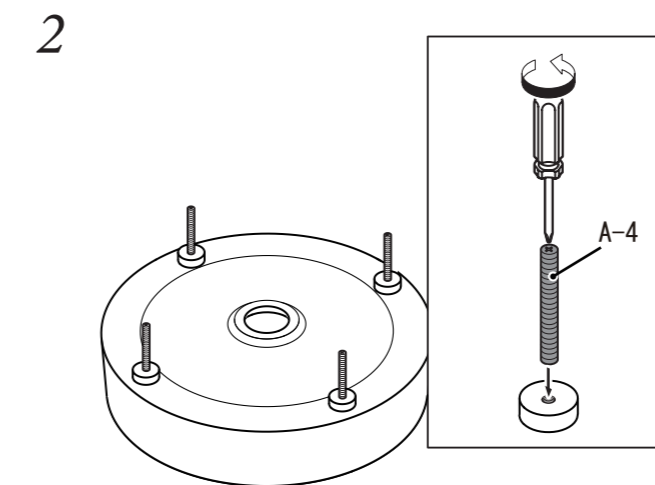
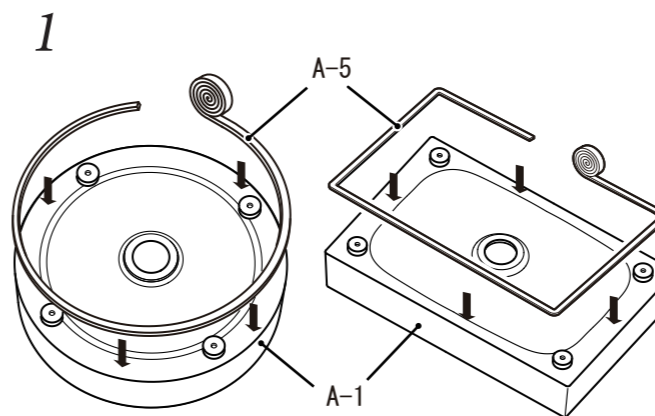

Attach the water discharge main unit Anbringen des Wasserabfluss- Hauptgeräts Fixez l'unité principale d'évacuation de l'eau Installare l'unità principale di scarico acqua

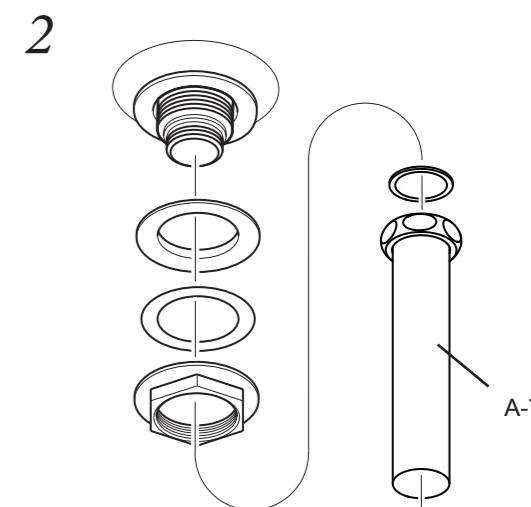
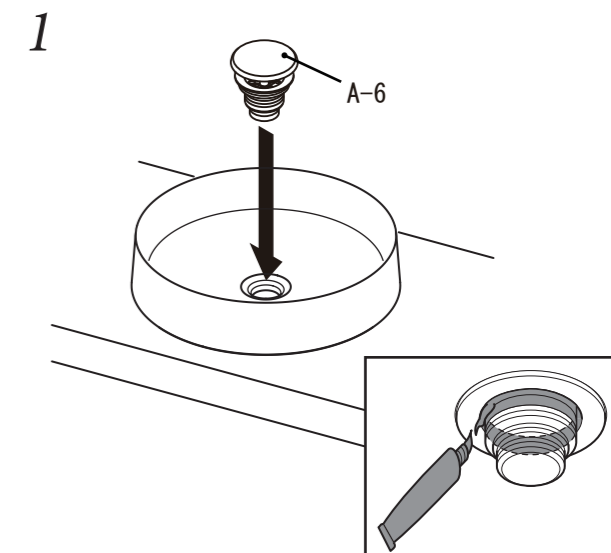

Finishing Fertigstellung Finition Operazioni finali

